



FAURE
ÉQUIPEMENTS
ΕΠΙΒΕΒΗΝΙΣ

“Hydra” series Feed Pumps

**SELF-REGULATING PISTON/MEMBRANE
PRESSURE PUMPS FOR 10 TO 15 m³/H**

Advantages of Hydra pumps:

- Ideal for feed to filter presses
- Automatic flow rate/pressure regulation. Pmax: 16 bars
- Suitable for all types of abrasive and corrosive product
- Simple, robust and durable
- Option for parts to be made of stainless steel
- Option to adjust the final filtration pressure
- Pump stops automatically in the event of accidental rupture of a membrane (available as an option)
- Energy saving

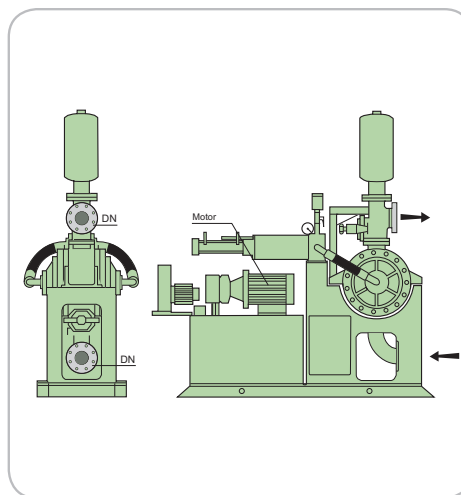

DESIGN

- Constructed by mechanical welding, cast iron pump body, plunger piston coupled to a hydraulic jack operated by a hydraulic unit, itself moved by the piston, ensuring regulation of the flow rate/pressure
- Membranes operated by the displacement of a volume of oil.
- Direct passage suction and discharge box with polyurethane seats and stainless steel balls.
- Damping ball on discharge side.

HYDRA	FLOW RATE (L/HOUR)	POWER (Kw)
SH 10	10000	5,5
SH 12	12000	5,5
SH 15	15000	7,5

www.faureequip.com

FAURE EQUIPEMENTS SA - Registered office and factory - ZI Magré - 21, rue Santos-Dumont - BP 52 - F-87002 LIMOGES
CEDEX 1 - FRANCE - Tel.: +33 (0)5 55 30 12 60 - Fax: +33 (0)5 55 06 16 03 - Email: mail@faureequip.com



FAURE
ÉQUIPEMENTS
EQUIPMENTS

“Cotre” series feed pumps

SELF-REGULATING PISTON/MEMBRANE PRESSURE PUMPS FOR 750 L/H TO 7.5 m³/H

Advantages of Cotre pumps:

- Ideal for feeding filter presses
- Automatic flow rate/pressure regulation. Pmax: 16 bars
- Suitable for all types of abrasive and corrosive product
- Option to manufacture the parts in contact with the product in stainless steel
- Simple, robust and durable
- Ease of maintenance
- Option to adjust the final filtration pressure

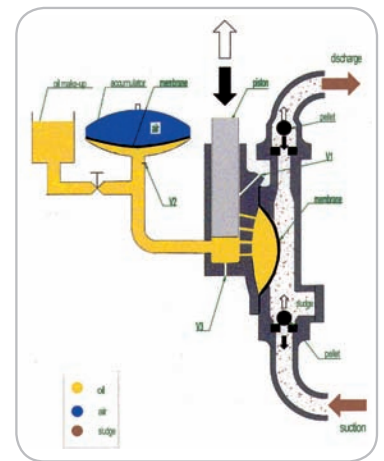

DESIGN

- Constructed by mechanical welding, with cast iron or stainless steel pump body.
- A piston operated by a crankshaft system displaces a volume of oil, which acts directly on a membrane. This membrane is alternately sucked in and out. The product is transferred by 2 ball valves.
- Regulation of the flow rate as a function of the pressure: the system allows the maximum flow rate to be delivered at any time, depending on the discharge pressure in the circuit. The pressure flow rate curve is adjustable. A compensation and braking mechanism prevents violent or sudden movement.

COTRE	FLOW RATE L/HOUR	PISTON MM	POWER Kw
750	750	60	1,5
1000	1000	60	2,2
1500	1500	80	3
2000	2000	80	3
3000	3000	100	4
4000	4000	100	5,5
6000	6000	120	5,5
7500	7500	120	7,5

www.faureequip.com

FAURE EQUIPEMENTS SA - Registered office and factory - ZI Magré - 21, rue Santos-Dumont - BP 52 - F-87002 LIMOGES
CEDEX 1 - FRANCE - Tel.: +33 (0)5 55 30 12 60 - Fax: +33 (0)5 55 06 16 03 - Email: mail@faureequip.com